

# Inspection of Frozen-Formed Products



**The X39 x-ray system is specifically designed for the inspection of unpackaged, frozen-formed products. The x-ray system ensures your products are free from contaminants and any product defects, assisting with meeting industry standards.**

#### **Unsurpassed Detection of Contaminants**

The X39 x-ray system's two-stage inspection process detects and rejects contaminants such as calcified bone, glass, metal, mineral stone, high density plastics and rubber within products such as burger patties (meat, poultry, fish or vegetarian) and other frozen-formed products.

#### **Uniquely Flexible Solution**

Designed for the accurate inspection of unpackaged, frozen-formed products even when the product positioning on the belt varies. The laser will inspect for product

flakes, product length, width and height as a preliminary check before entering the inspection zone where the x-ray will inspect products for contamination, holes, dents, edge deformities and shape defects.

#### **Minimise Product Waste**

Any non-conforming product is quickly and effectively removed from the production line through a multi-nozzle air blast reject system or via the failsafe reject flap allowing removed product to be re-worked, minimizing waste and improving overall product quality.

# X39

## The Big Difference is in Every Detail

The X39 x-ray system not only offers outstanding contamination detection but also provides a range of additional features and benefits.

### Design

- A 800mm wide belt ensures that high throughputs can be achieved at speeds of up to 57 metres/ min.
- In addition to contamination detection a range of inline x-ray quality checks will remove any non-conforming product from the process. These checks include mass measurement, dent and hole inspection, shape checks and edge defects.
- Specially designed laser can detect flakes\* on top of the product and any variation in the height, width and length of the product.
- The X39 can be installed immediately after a freezer tunnel via a spacing conveyor minimizing line space required.
- A fully integrated two-stage reject system across multiple lanes minimizes product waste, providing complete product protection.

### Hygienic Design

- Class-leading hygienic design following GMP, NSF and EHEDG principles and compliance with FDA regulations and EU Directives.
- IP69 design as standard for harsh wash down environments.
- 316 stainless steel is used for all key product contact areas including, guides, reject flap and reject receptacles.
- Easy access to all machine areas ensuring minimum downtime required for cleaning and protection against any bacteria growth.

### Software Capabilities

- The intelligent set-up software of the X39 is sophisticated yet simple to use with a flat menu structure giving full operator control without the need for advanced training.
- The software monitors all aspects of the X39 and

provides pre-warnings of the accuracy of the lasers, reject nozzles and confirmation sensors.

### Audits / Verification

- Full statistics traceability for quality reporting.
- Performance verification built-in to ensure constant optimum performance.
- Flexible approach to connectivity is offered with options for data retrieval via external USB or internal Ethernet ports.

### 5 Year Generator Warranty\*\*

- A 5 Year Generator Warranty covers the most expensive component of the X39 avoiding unexpected costs and production downtime.
- Budgets can be effectively managed with the warranty, fully protecting the investment.



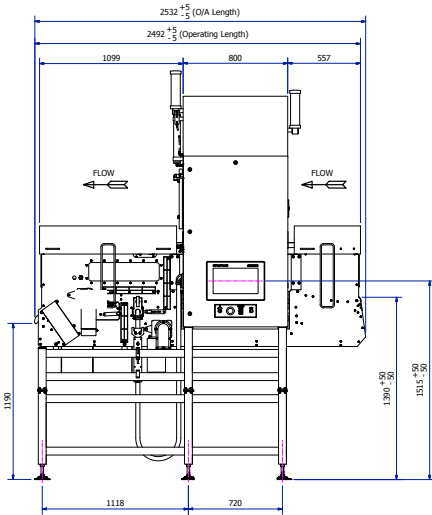

X39 - 2532mm long

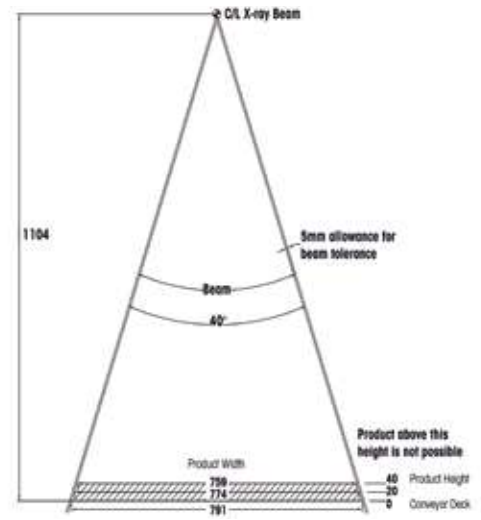
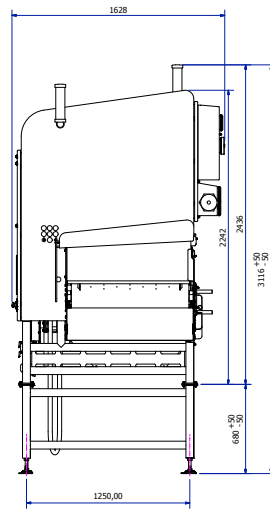

Product size diagram for the 800mm detector width

## X39 Software Tools

The X39 x-ray system can inspect for contamination and a range of product defects whilst simultaneously storing all images and inspection history, ensuring all quality assurance requirements are met.

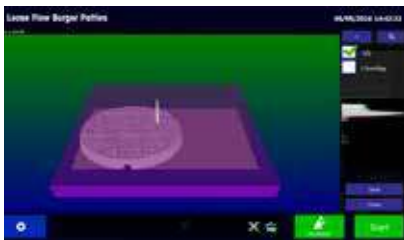

### Unsurpassed Detection of Contaminants

The X39 provides outstanding detection and rejection of contaminants in various frozen-formed applications such as burger patties (meat, poultry, fish and vegetarian).

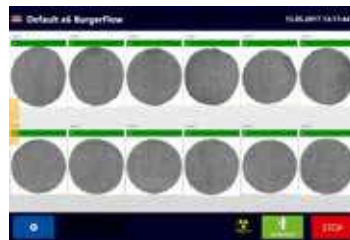

### The Widest Range of Product Integrity Checks

Offering accurate inspection of products for flakes, length, width and height variances, mass, dents, holes, edge defects to ensure only conforming product is accepted.



### Meeting Due Diligence Requirements

ProdX data management software can integrate all Product Inspection Systems on the production line by providing multiple methods to interact with the system to retrieve critical inspection process data that can be stored in one convenient location. (e.g. statistics and images)

## Class Leading Hygienic Design

The importance of achieving and maintaining high hygiene standards is ever increasing, the public are more aware of the risks associated with bacterial outbreaks and the consequential potential damage to your brand should a product recall be required.

Hygienic design principles are applied to the complete system, including 316 stainless steel used for key product contact areas. An open frame design, angled surfaces and easy belt removal all assist with achieving the manufacturing demands of high pressure wash-downs and thorough system cleaning. Good system design helps food manufacturers meet HACCP requirements and comply with industry standards.



Burger patties approaching the X39 x-ray inspection system

## Reject Mechanism

A fully integrated precision air nozzle reject system allows for a specific product to be rejected rather than product across the full belt width. The air nozzles are mounted at an angle and aim towards the product flow, removing the contaminated product off the line via a pre-programmed gap and into the primary reject rework bin, minimizing product waste and saving costs.

If the product is too large to fit through the pre-programmed gap, e.g. two patties joined together, a failsafe reject flap will remove any remaining product from the production line. Defective product can then be reworked as required. This stage often involves further product inspection using a bulk flow x-ray system.



Multi-air nozzle reject system

## Specification Table

Feature	Specifications
Conveyor Speed	Typical line speeds 10-57 m/min
Lane Configurations	Up to 7 unguided lanes
Throughput Rate	Typical throughput rates up to 1800 products per minute (dependent on product dimensions)***
Maximum Product Height	40mm
X-ray Detector	800mm
X-ray Generator	420W, 84kV, 5.0 mA Beryllium tube
X-ray Beams	Single beam
X-ray Emissions	< 1uSv/hr
X-ray Protections	Fully contained emissions within construction, ramp up/ down construction, shutdown plates to 50mm height
Laser	3D linescan, Class 3B (IEC 60825-1 : 2008-01)
Cooling Method	Heat exchanger and radiator pump
Operating Humidity	Up to 90% RH
Operating Temperature	5 – 40°C
Power Supply	208 - 240 Vac, 1 phase, 50-60 Hz, 10 A
Pneumatic Supply	6 Bar(g) clean air supply required for air operated reject system
Casing Material	304 stainless steel (316 on key contact areas)
Finish	240 Grit Brushed on main components
Ingress Protection	IP69 as standard
Operating Height	1400mm infeed (Note: the outfeed is 200mm lower than infeed height)
Inspection Conveyor	FDA and EU food use approved TPU conveyor belt, 0.55 kW motor unit, 50 mm diameter roll ends
Reject Conveyor	FDA and EU food use approved PP modular belt, 0.37 kW motor unit, 82 mm diameter roll ends
System Length	2532mm
Screen Display	15.6" LED touchscreen display (16:9 ratio)
Reject Type	Integrated airblast reject with failsafe reject flap
Reject Bin	Option reject bins or reject chute
Operating System	Microsoft Windows 64 bit
Unique Inspection Tools	Holes, dents, edge defects and shape (x-ray) plus flake and height, width and length (laser)
Connectivity Options	Ethernet (internal), USB (external)
Traceability Options	Full event log tracks changes of parameters, users and products
Guide Rails	Infeed guide rails

\*\*\*The X39 operates at 57 metres a minute. For example: it can conduct 10 integrity checks of 300 pieces a minute per lane based on 100mm patties across 6 lanes, with approximately 100mm gap between each product.

### Mettler-Toledo Group

Product Inspection Division  
Local contact: [www.mt.com/contacts](http://www.mt.com/contacts)

[www.mt.com/safeline-xray](http://www.mt.com/safeline-xray)

For more information

Subject to technical changes  
© 06/2017 METTLER TOLEDO. All rights reserved  
PI-XR-DS-EN-062017

