

X38 Series Pipeline Inspection of Pumped Products



The X38 x-ray system is designed to inspect pumped food products, typically liquids, slurries and pastes before further value is added to the product through processing and final packaging.

Superior Product Safety

The X38 delivers outstanding contamination detection of foreign bodies such as glass, metal, mineral stone, calcified bone, high density plastic and rubber compounds.

High Throughput

The x-ray system is capable of inspecting typical throughputs of up to 14 tonnes per hour, depending on pipe diameter and flow rate, without damaging the product.

Automatic Calibration

The system automatically calibrates in less than 20 seconds as the x-ray generator and detector simultaneously retract from the inspection window, without the need of manual intervention.

Robust Design

The robust system design offers easy access to all areas and is suitable for harsh wash-down environments with a IP69 sealing as standard, including a class leading IP69 air conditioner.

X38 Pipeline

The Big Difference is in Every Detail

The X38 x-ray system not only offers outstanding contamination detection but also provides many other valuable features and benefits.

Software Capability

- Sophisticated yet simple to use, giving the operator full control without requiring special training or previous x-ray knowledge.
- Simple set-up, ensuring maximum production uptime.
- Full statistics for quality reporting.

Design

- Easy calibration - the x-ray generator and detector are on a moving carriage allowing it to be rolled backwards during a product calibration, eliminating the need to disconnect the pipe work.
- Superior reliability due to its modular component construction and unique x-ray generator thermal cooling design.

- Easy integration into existing production lines due to the small footprint and bespoke design.

Flow Rates

- Continuous flow rate of up to 14 tonnes per hour, depending on pipe diameter and application.
- 63mm (2.5"), 75mm (3") and 100mm (4") diameter pipes are available as standard to suit varying throughputs (other pipe diameters are available).
- The flow rate signal from the customer's pump can automatically change the scan speed and the reject timings of the X38 to match the customer's flow rates.

Product Testing

- Auto test facility option - a contaminant sample i.e. a stainless steel sphere moves

through the beam and verifies level of detection - no need to insert test pieces into the pipe.

Connectivity

- Flexible approach to connectivity is offered with options for data retrieval via external USB or Ethernet ports directly or via Ethernet IP or ProdX.

5 Year Generator Warranty*

- A 5 Year Generator Warranty covers the most expensive component of the X38 Series avoiding unexpected costs and production downtime.
- Budgets can be effectively managed with the warranty, fully protecting the investment.



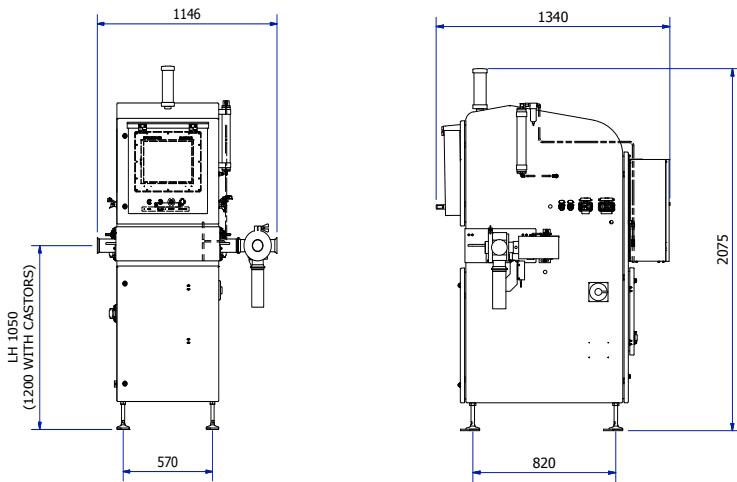

X38 - 1146mm long

Aseptic Manifold

The X38 is designed to withstand IP69 in-line aseptic cleaning, ensuring the highest possible hygienic design standards.

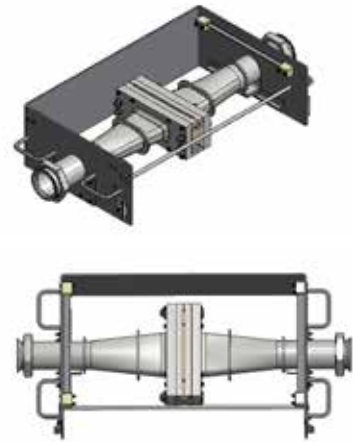

Manifold can be quickly removed for easy cleaning

X38 Pipeline

The X38 Pipeline x-ray system can inspect for contamination whilst simultaneously storing all images and inspection history, ensuring all quality assurance requirements are protected.



Market Leading Hygienic Design

The X38 Pipeline encapsulates customers requirements of outstanding detection capabilities and IP69 hygienic design as standard. Sloped and curved edges allows for water roll off whilst the IP69 air conditioner meets the demands of high pressure cleaning in harsh manufacturing environments.



Meeting Due Diligence Requirements

ProdX data management software can integrate all Product Inspection Systems on the production line by allowing multiple methods to interact with the system to retrieve critical inspection process data e.g. statistics and images and store them in one convenient location.

Typical X38 Pipeline Applications

Industry Segments	Products
Bakery	Jams, Syrups, Cake Mix and Fillings
Confectionary	Melted Chocolate, Nougats, Toffees, Sugars
Dairy	Butter, Ice Cream, Yoghurt, Curd
Fish and Seafood	Fish Spread, Processed Fish for Ready Meals
Fruit and Vegetables	Purees, Mousse, Compotes, Juices, Smoothies, Chopped Fruit and Vegetables
Meat and Poultry	Minced Meats for Sausages, Poultry, Pies and Pasties, Patés
Personal Care	Creams and Lotions, Soaps
Pharmaceutical	Slurries, Creams
Ready Meals	Sauces, Pie Fillings, Soups

Reject Mechanism

There are a number of different fully integrated high-speed reject valves available. The correct choice depends on a number of factors such as type of environment, product speed and product type. Reject valves can be synchronised to the pump, minimising the rejected portions.



Reject Valve Example:
Three-way Ball Valve

Specification Table

Feature	Specifications
Flow Rate	Up to 14 tonnes/ hour (depending on application and pipe diameter)
Pipe Diameter	2.5", 3.5" or 4" (63mm, 75mm and 100mm) as standard, other pipe diameters are available
X-ray Detector	300mm, 0.8mm diode size (0.4mm optional)
X-ray Generator	270W, 60kV, 4.5mA Glass
X-ray Beams	Single
X-ray Emissions	< 1uSv/hr*
X-ray Protections	Fully contained emissions within construction, provided up and downstream pipes
Cooling Method	IP69 Air Conditioner
Operating Humidity	30% RH - 85% RH
Operating Temperature	5°C - 40°C
Operating Pressure in Pipe	3 bar typical, 10 bar peak
Power Supply	208 - 240 Vac, 1 phase, 50-60 Hz, 6 A
Pneumatic Supply	6 Bar(g) clean air supply required for air operated reject system
Casing Material	304 stainless steel, pipeline manifold 316 stainless steel
Finish	180-240 Grit Brushed on main components
Ingress Protection	IP69
Operating Height	1000mm +/- 50mm (feet) or 1200mm +/- 50mm (castors)
System Length	900mm over manifold, pipework varies
Screen Display	15" LED Touchscreen display (16:9 aspect ratio)
Reject Type	Pneumatically controlled valve
Reject Bin	Interlocked pipe for reject path
Operating System	Microsoft Windows 64 bit
Connectivity Options	Ethernet connection available
Traceability Options	Full event log tracks changes of parameters, users and products

*Safe integration with up and downstream pipes. Equipment may require additional customised design.

Mettler-Toledo Group

Product Inspection Division
Local contact: www.mt.com/contacts

www.mt.com/safeline-xray

For more information



Subject to technical changes
© 04/2018 METTLER TOLEDO. All rights reserved
PI-XR-DS-EN-042018